



Benefits

- Ultra-Quiet
- Power sensitive electronics without interference
- Rugged & Reliable
- Ensure years of safe and trouble free operation

Applications

- Oil Patch
- Mobile Offices (TV and Radio Vans)
- Marine / Automotive / RV
- Industrial Controls (OEM Applications)
- Computer Systems
- Field Work / Construction Sites
- Solar / Alternative Power Systems
- Run any 5V or 12V Equipment

Description

DC Battery Chargers

BCD72 Series DC Battery Charger

The BCD72 Series Battery Charger supplies 13.6 or 27.2 Vdc from 24/32, 48 or 72 Vdc power systems for use in heavy equipment, marine, industrial, or alternative energy environments. The BCD72-12-5 version is capable of supplying 5 Volts from a 12 VDC battery system.

State of the art Switch-mode design offers high reliability, high efficiency, and minimum size.

The unit has reverse input protection, output current limiting and output overvoltage protection.

Features

- Input voltage range allows operation from 12, 24/32, 48 or 72 volt power systems
- Reverse input protection
- Extremely rugged and well suited for marine and other demanding environments
- High tolerance for shock and vibration
- Short circuit protection
- Output over-voltage crowbar
- Inrush Current Limiting (except BCD72-12-5)
- Easily Mounted
- Wide operation Temperature range
- Remote On-Off version available (call factory for details)
- Conformal Coating and/or Harsh Environment Ruggedization Available
- 3 year parts and labour warranty

BCD72 Series DC Battery Chargers

Mechanical Diagram

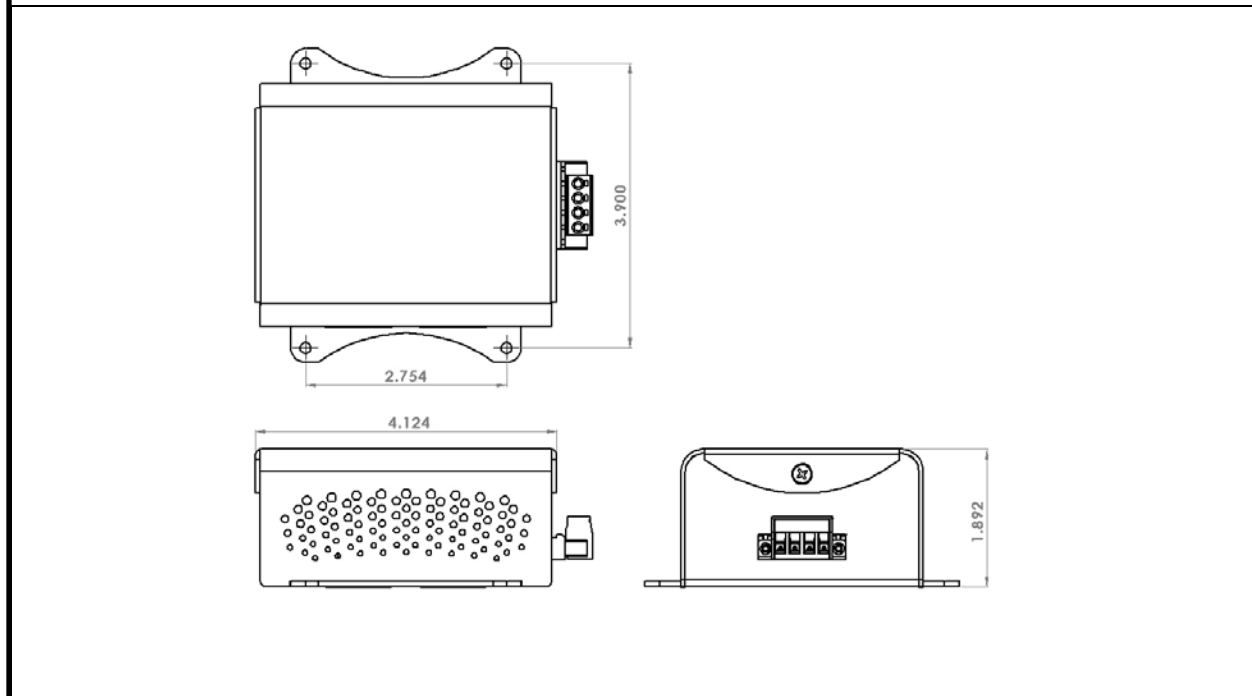

Specification

Electrical (Input)

Input Volts (ip)	◆12	24/32	48	72
Actual (Vdc)	11-16	◆◆20-45	40-65	65-100
Input Amps (max)	3.7	5.4	2.7	1.7
Input Fuse (5TT)	6	8	4	3
Noise on Input	< 10 mV			

◆ BCD72-12-5 version

◆◆ 30 – 45 Vdc input range for a 24Vdc output.

Environmental Specification

Operating Temp. Range	-20 to +50 °C @ maximum output Derate Linearly 2.5% per °C from 40°C (Optional -40°C extra wide temp. operation avail.)
Humidity	0 – 95% Relative Humidity (non-condensing) with optional conformal coating
Audible Noise	NONE ØdB @ 3ft
Typical Service Life	> 10 yrs. (87.600hrs)
Isolation	Any Input or Output to Case 500 VDC 1500 VDC for 48 and 72 Input Input to Output – Common Negative

Electrical (Output)

Output Nominal (op)	◆ 5	12	24
Output Volts (DC)	5.0 ± 1%	13.6 ± 1%	27.2 ± 1%
Output Crowbar(V)	7.0 ± 0.5	16.0 ± 0.5	32.0 ± 1
Output Amps Cont (A)	5.3	5.3	2.6
Output Amps Peak (A)	6.5	6.5	3.25
Output Fuse (5TT)	8	8	4
Output Ripple & Noise	< 10 mV		
Transient Response	< 1V for 50% Surge		
Regulation (Line & Load)	< ± 0.5%		
Durability	Peak 20% for 10 min maximum Continuous 100% for 24 hours per day		
Efficiency	> 88% @ Maximum Output		

Mechanical Specification

Length	4.57 in / 11.6 cm
Width	4.12 in / 10.5 cm
Height	1.92 in / 4.88 cm
Material	Marine Grade Aluminium
Finish	Black Anodize / Powder Epoxy Coat
Fastenings	All 18-8 Stainless Steel
Weight	0.64 lb / 0.29 kg
Connections	Four contact output terminals
Warranty	3 years

Available From: